

Montageanleitung

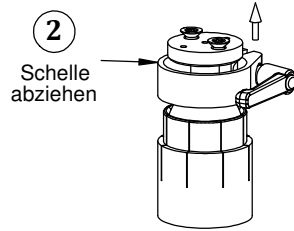

Klemmhebel bei Bedarf durch beiliegende Schraube und Mutter ersetzen

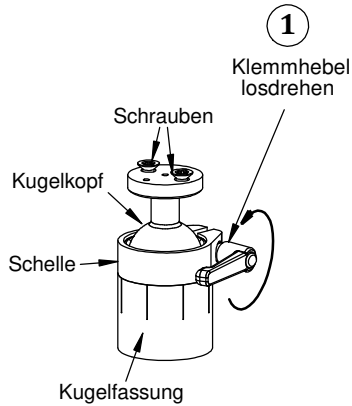
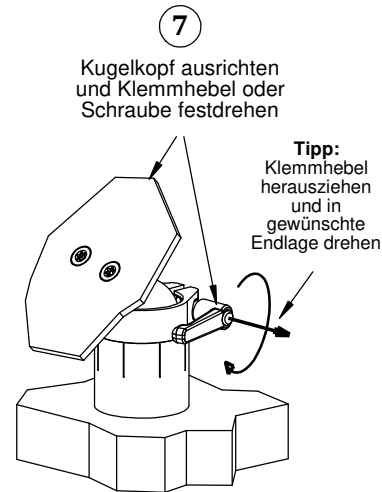
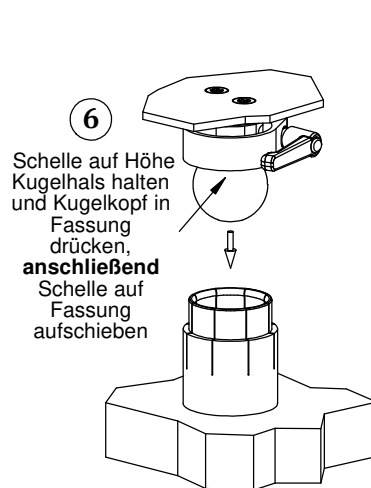
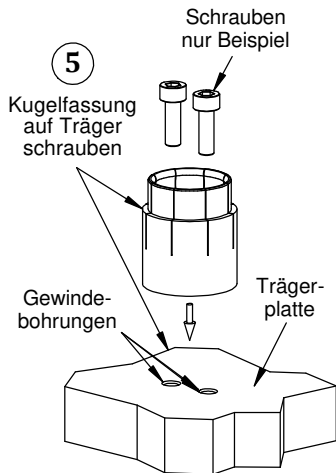
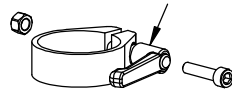

HERMANN
MECHATRONIK

Inh. Stefan Hermann
Prinz-Eugen-Str. 81
88069 Tettnang
Deutschland

www.hmqr.de

Technische Änderungen behalten
wir uns ohne Vorankündigung vor.
104720C / 180302

KGH G40 mit Pl. VESA 75 silbern

Art.-Nr.:
H4030